

JDN ENERGY SUPPLIES

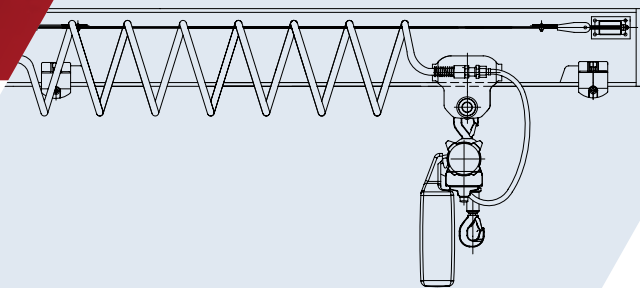

A series of supply systems are available for powering JDN Air Hoists in trolleys, monorail hoists and crane systems:

- Hose trolleys
- Spiral hose
- Square bar or C rail
- Energy chain

HOSE TROLLEYS

The hose is fastened to trolleys, which roll directly on the bottom flange of the beam. With each horizontal move of the hoist along the beam, the hose trolleys make the hose follow suit. The hose trolleys will be used for short distances or if there is not enough space on the side of the beam to install C or square bars.

YOUR ADVANTAGES:

- Easy to install
- Cost-efficient
- Consisting of: Hose carriages and hose

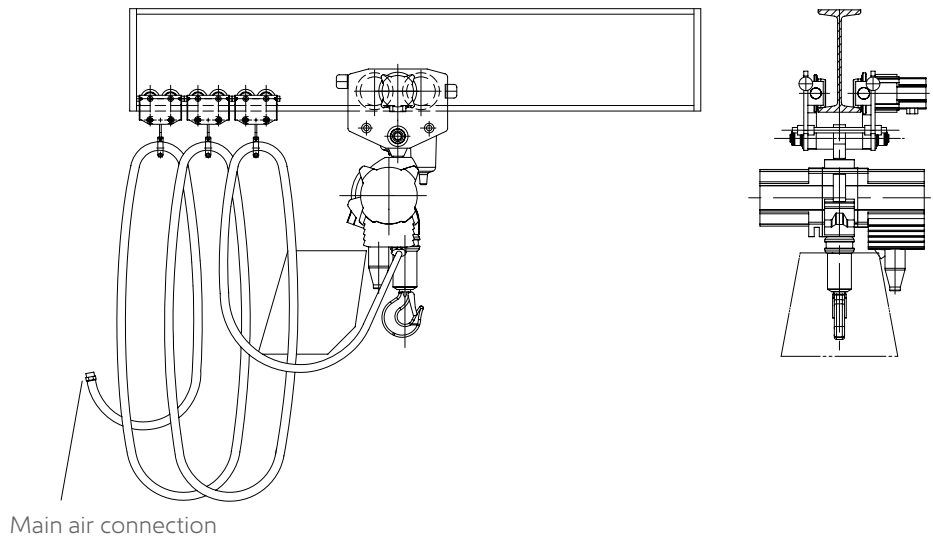

SPIRAL HOSE

This simple and economical solution is suitable for distances of up to 10 metres. The hose rings are suspended on a plastic-coated rope that runs parallel to the track.

The spiral hose can be used in category 3 (zone 2) with gases in explosion group IIA and IIB. It is not suitable for applications in category 2 (zone 1) or group IIC.

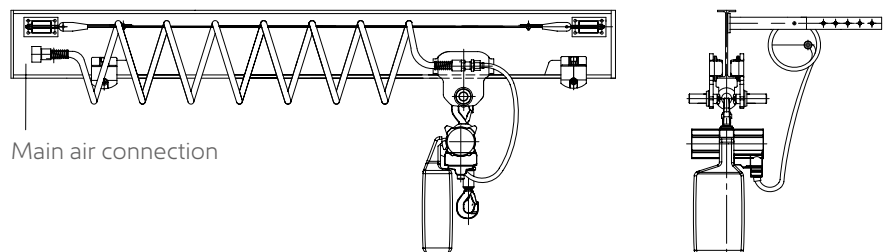

Practical tip:

Make sure to lay the hose so that its extended length is roughly 1.5 times the required distance.

- Consisting of: Tensioning arms, rope tensioners, hose and rope

SQUARE BAR & C RAIL

Galvanised C rails or square bars are installed along the beam to carry the energy supply lines.

SQUARE BAR

Depending on the local conditions, rails and curved tracks of different lengths are available, as well as an extensive range of installation accessories. The square bar is also suitable for curved tracks.

- Consisting of: Square bars, tensioning arms, hose, hose supports and supply line carriages

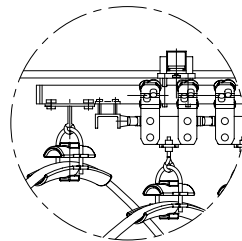
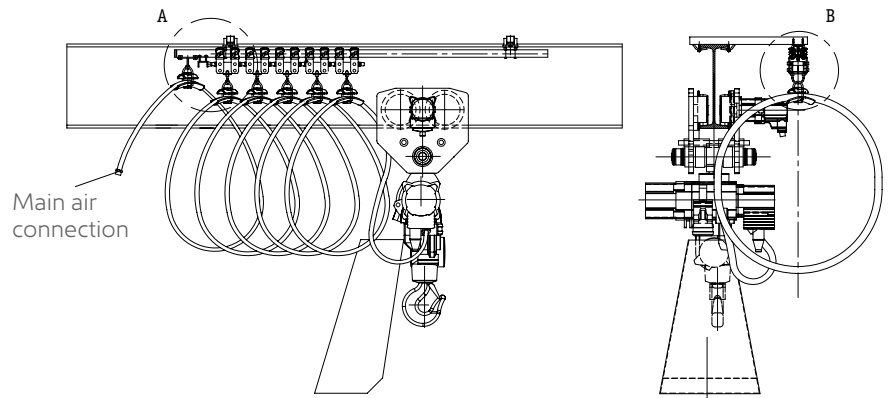

Detail A

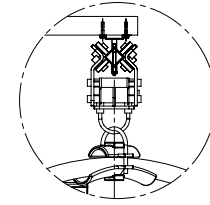

Detail B

C RAIL

- Consisting of: C rails with support, adapter, antistatic supply hose and hose support. The supports must be attached to the upper flange of the beam.

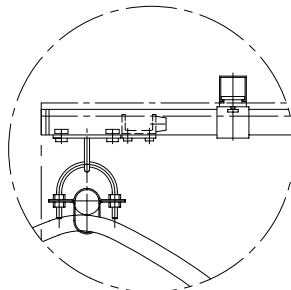
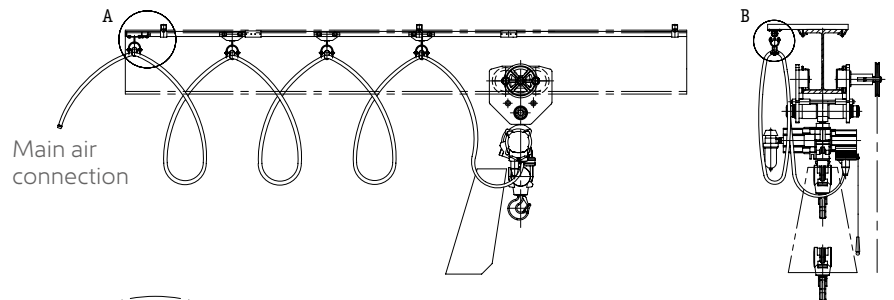

Detail A

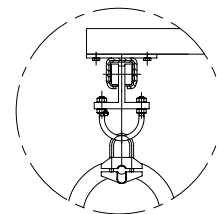

Detail B

ENERGY CHAIN

DIE ENERGY CHAIN FOR TROLLEY DRIVE OF OVERHEAD TRAVELLING CRANES

The energy supply for trolley drive in overhead travelling cranes is realised by a horizontal version of the energy chain. A guide channel is mounted on the girder with the chain gliding inside. Air distribution and the control box are also attached to the guide channel. Usually there are two different types of hoses inside the energy chain: The air hose, which feeds the hoisting motor and the trolley motor, and the control hose for crane control functions.

In case of low headroom requirements choose vertical installed energy chain, like the supply for trolleys in underslung cranes.

ENERGY CHAIN FOR CRANE DRIVE OF OVERHEAD TRAVELLING CRANES

The energy supply for crane drive in overhead travelling cranes is realised by a vertical installation of the energy chain. The necessary guide channel system is mounted with clamped brackets on the bottom flange. If different profile sizes for the bottom flange are used because varying in support spacing, the brackets may be clamped to the top flange. The clamped brackets can be used for all the normal steel girder sections (with flange thickness 7-40 mm (0.28-1.57inch)).

The energy chain carries air hoses inside, which supply the hoisting motor, driving motors as well as the control hoses of the crane. In addition it is possible to install further control hoses and electric cables inside the energy chain.

The main air connection of the energy supply is located midway of the crane travel distance.

ENERGY CHAIN FOR TROLLEY AND CRANE DRIVE OF UNDERSLUNG CRANES

The energy supply for hoists with trolley and for crane drives in underslung cranes is realised by a vertical installation of the energy chain. The guide channel system is mounted with c-panels, which are clamped by claws on the top flange of the girder. The dimensions of the c-panels are depending on the used girder.

Supply air hoses for hoisting and travelling as well as control hoses are installed in the energy chain.

